

# talk funny?

## ring modulator, chopper and frequency modulator

Deliberate electronic distortion of speech and music signals can give fascinating results. Professional musicians use extremely expensive equipment to obtain their very own weird and wonderful 'sound'. For electronics enthusiasts, it is much more fun to get the same sort of results from very simple circuits. Which is what this article is about: getting effective effects using a single IC, the 2206.

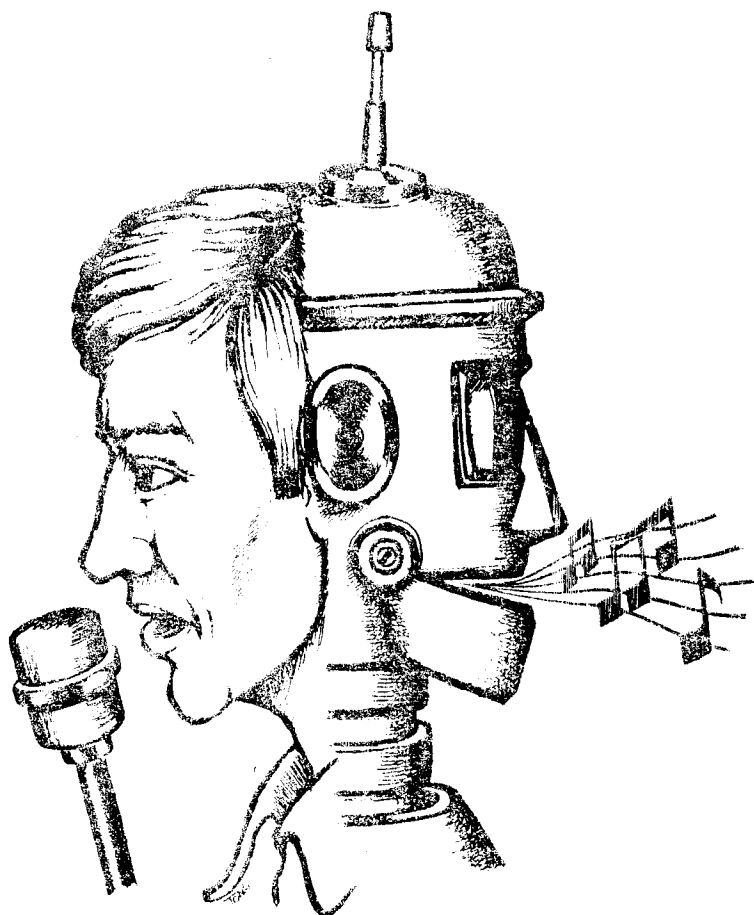

One of the best known and most impressive distorters for audio signals is the ring modulator. Normally speaking, a ring modulator circuit has two inputs: one for the audio signal (speech, for instance) and one for a 'carrier'. The weirdest effects are obtained when the carrier frequency is within or just above the audio range; using different carrier shapes (sinewave, squarewave or triangular waveform) can produce different effects.

The circuit can be drastically simplified by using a 2206. This contains a tunable generator for the carrier, and a multiplier circuit that is ideally suited for use as a ring modulator. The internal block diagram is shown in figure 1.

The oscillator (VCO) is already connected internally to the multiplier. This means that, basically, applying an audio signal to the other multiplier input (pin 1) will produce a 'ring-modulated' output at pin 2. Simplicity itself!

Obviously, a few other components are needed in a practical circuit. Not many, though, as shown in figure 2. A sine capacitor, C4 (C<sub>EXT</sub> in figure 1), determines the frequency range of the VCO. With the value given, the 1M potentiometer (P1; R<sub>EXT</sub> in figure 1) can be used to set any frequency between approximately 10 Hz and 10 kHz. The wave-shape is selected by means of S1: switch closed for sinewave, switch opened for triangle.

The audio input signal is fed to the modulation input via C1. A voltage divider circuit (R1, P2, R2) sets two DC bias levels: the voltage across C2 provides the basic internal DC reference, and P2 is used to adjust the operating point of the multiplier. This adjustment is important: it determines the 'carrier level' (the output from the oscillator)

Table

Technical data for the complete circuit (figure 3):

Functions:  
Ring modulator  
Chopper  
Frequency modulator

Frequency range of VCO:  
Low range: 1 Hz ... 300 Hz  
High range: 100 Hz ... 20 kHz

Frequency modulation:  
± 30% frequency swing for 1V top-to-top modulation signal.

Impedances:  
Input: 30 k  
Output: 2 k

Signal levels:  
Input, nominal: 1 V<sub>eff</sub> (350 mV RMS)  
maximum: 8 V<sub>eff</sub> (2.8 V RMS)  
Output, maximum: 10 V<sub>eff</sub> (3.5 V RMS)

Supply:  
12 V, stabilised; 30 mA max.

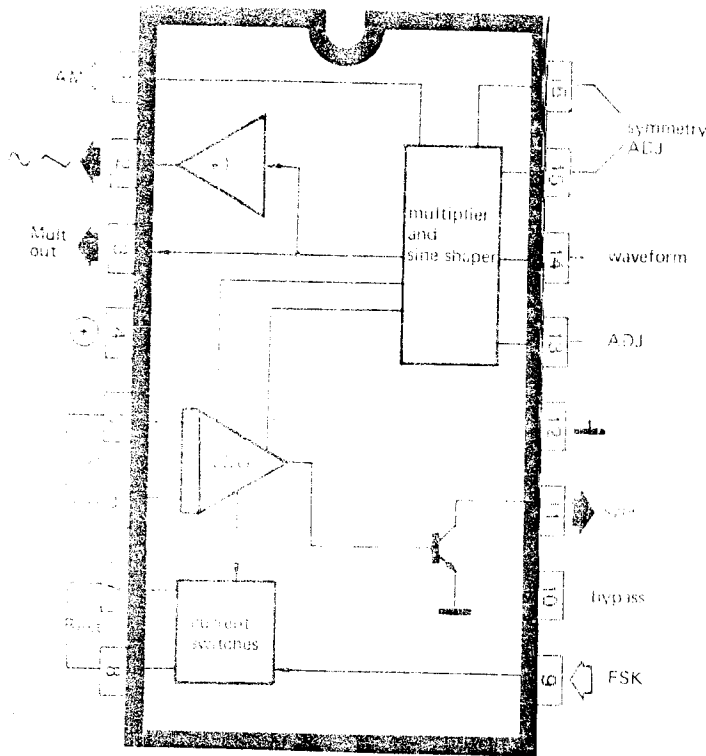

Figure 1. Internal block diagram of the 2206. This IC is a complete function generator, containing a VCO and a multiplier. The latter is ideally suited for use as a ring modulator.

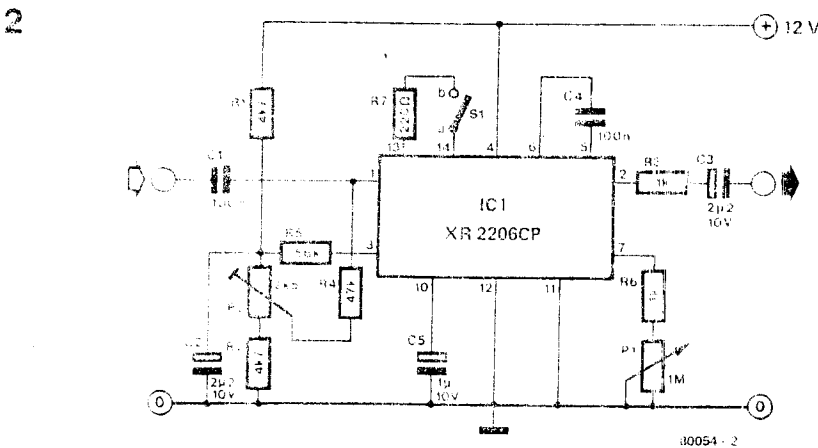

Figure 2. A simple circuit, using the 2206 as a ring modulator.

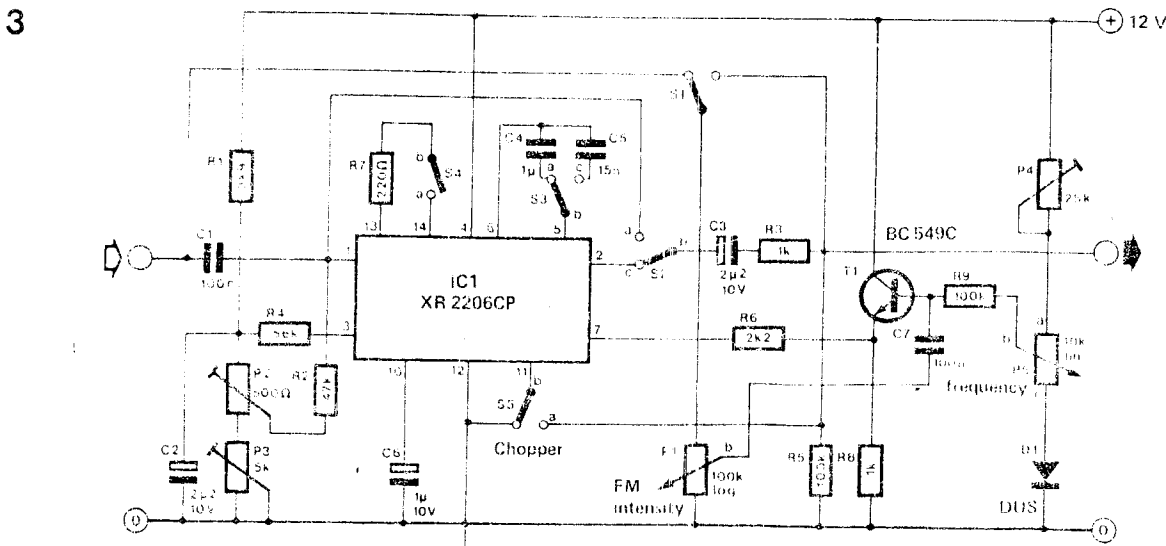

Figure 3. The simple circuit given in figure 2 can be extended as shown here. The 2206 is now used to the full: the input signal can be ring modulated and/or frequency modulated and/or chopped.

present in the final audio output. The easiest way is to short the audio input and then adjust P2 for zero audio output. Only then is the circuit operating as a true ring modulator. If P2 is incorrectly set, the oscillator frequency will appear at the output, amplitude modulated by the input (speech) signal. This can give interesting effects, but it isn't really the intention!

A stabilised supply must be used, otherwise the DC settings may drift. This would mean regular re-adjustment of P2 - which is rather a nuisance.

### Chopping and frequency modulation

The circuit can be extended, as shown in figure 3. Only a few additional components are needed to really use the IC to the full. Apart from adding the 'chopper' and 'frequency modulator' features, a useful linear frequency scale for the oscillator control is obtained as an additional bonus.

The basic ring modulator circuit is virtually identical to the circuit given in figure 2. The main difference is that the multiplier bias adjustment is improved: P3 is used for initial coarse adjustment, with P2 in the mid position; then P2 is used to tune out the last traces of the carrier.

The chopper circuit makes use of a squarewave output available at pin 11. To be more precise, this is the collector of an internal switching transistor (see figure 1). With S5 in position 'chopper', this point is connected to the signal output. When the transistor is turned on, the output is shorted; since the transistor is turned on and off periodically by the internal oscillator, the chopper frequency is determined by the setting of P5 (the VCO frequency control). Switch S2 can be used to select the audio signal before or after the ring modulator; note, however, that in the latter case the 'carrier' frequency for the ring modulator and the chopper

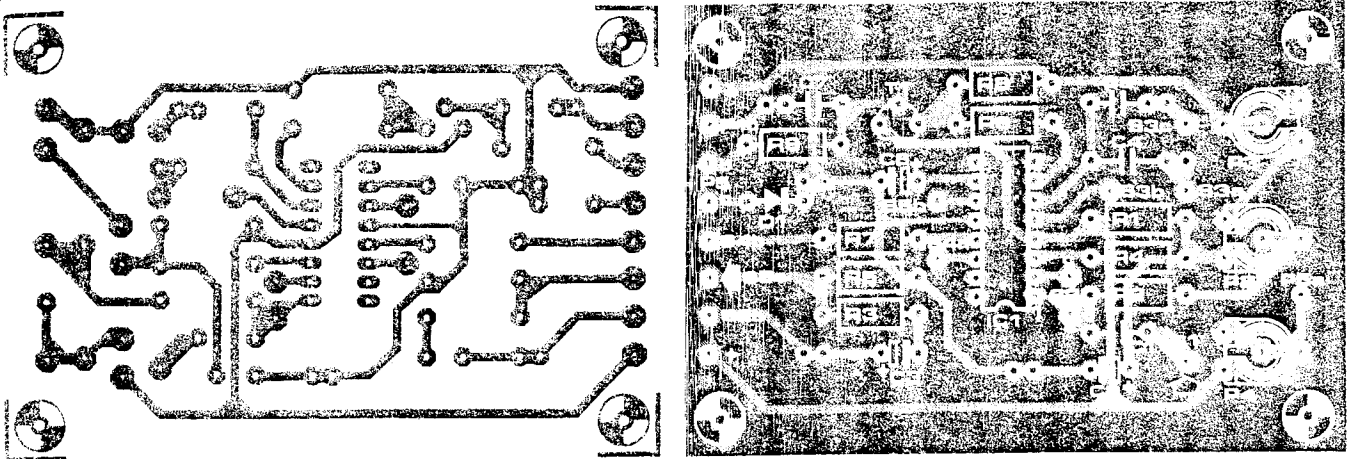
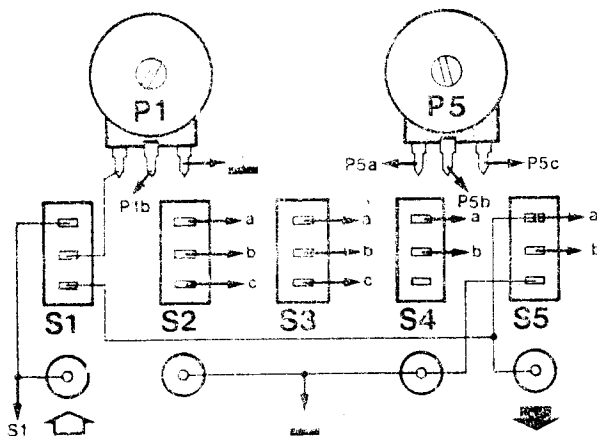

Figure 4. A possible printed circuit board layout for the complete circuit given in figure 3.

5



80054 5

6

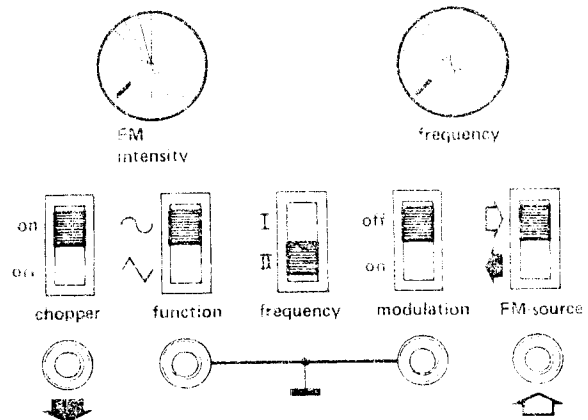

80054 6

Figure 5. Wiring diagram for the front panel controls. The small arrows indicate connections to the corresponding points on the board.

Figure 6. A suggested front panel layout.

frequency are identical — they are both derived from the same VCO.

The main reason for modifying the frequency control circuit for the VCO is to obtain a linear voltage control point. The frequency of the VCO varies linearly with the voltage at the base of T1; this voltage is determined by the setting of P5, but a frequency modulation signal can be superimposed via C7. P1 sets the modulation level; S1 is used to select either the audio input signal or the output signal.

The frequency control range is set by P4. The procedure is as follows. Turn P5 right up (lowest frequency) and set P4 to maximum resistance. C5 is switched into circuit via S3 and P2 is offset so that the oscillator signal appears at the output. P4 is now slowly turned down until the oscillator stops, and then turned back until it starts again reliably. This is the optimum setting. Once again, it depends on the supply voltage — so the latter must be stabilised.

7

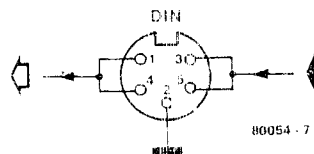

80054 7

Figure 7. A combined in- and output can be wired as shown here.

A simple supply using a 78L12, say, is adequate. A suitable circuit and p.c. board were given in Elektor, July/August 1978, p. 7-75.

A basic printed circuit board layout for the circuit itself is given in figure 4, and the two sides of the front panel with the controls are shown in figures 5 and 6. Finally, a suggestion for a combined in- and output connection is shown in figure 7. All of these drawings are included as suggestions only; the final design may be modified according to personal taste.

### How funny does it sound?

Sound effects are always difficult to describe — you've got to hear them. The

ring modulator 'sound' is perhaps the best known: all kinds of additional frequencies are added to the original signal, without any harmonic relationship. If really sharp dissonances are what you want, the 2206 ring modulator is just the trick!

The effect can be 'improved' by switching from sinewave to triangle: if you're not careful, you end up with a completely scrambled signal. On the other hand, using a low-frequency sinewave produces a more 'pleasant' sound — the ring modulator adds an interesting rhythmic effect to the original.

The chopper facility can be useful on its own, producing a kind of 'robot' or 'computer' sound. When used in combination with the ring modulator, the most weird results can be obtained. In the same way, combining frequency modulation with the ring modulator can be interesting: low modulation levels produce a kind of vibrato effect, and high modulation levels — well. Try it! ■